

**TRSS : A Three Reflection Sky Survey  
with an active optics telescope at Dome-C**

by Gérard R. Lemaître

Observatoire Astronomique Marseille Provence, LAM, LOOM  
2 Place Le Verrier, F-13248 Marseille CEDEX 04, EU

# 1. Review and Comparison of Wide Field Telescopes for Imaging Surveys

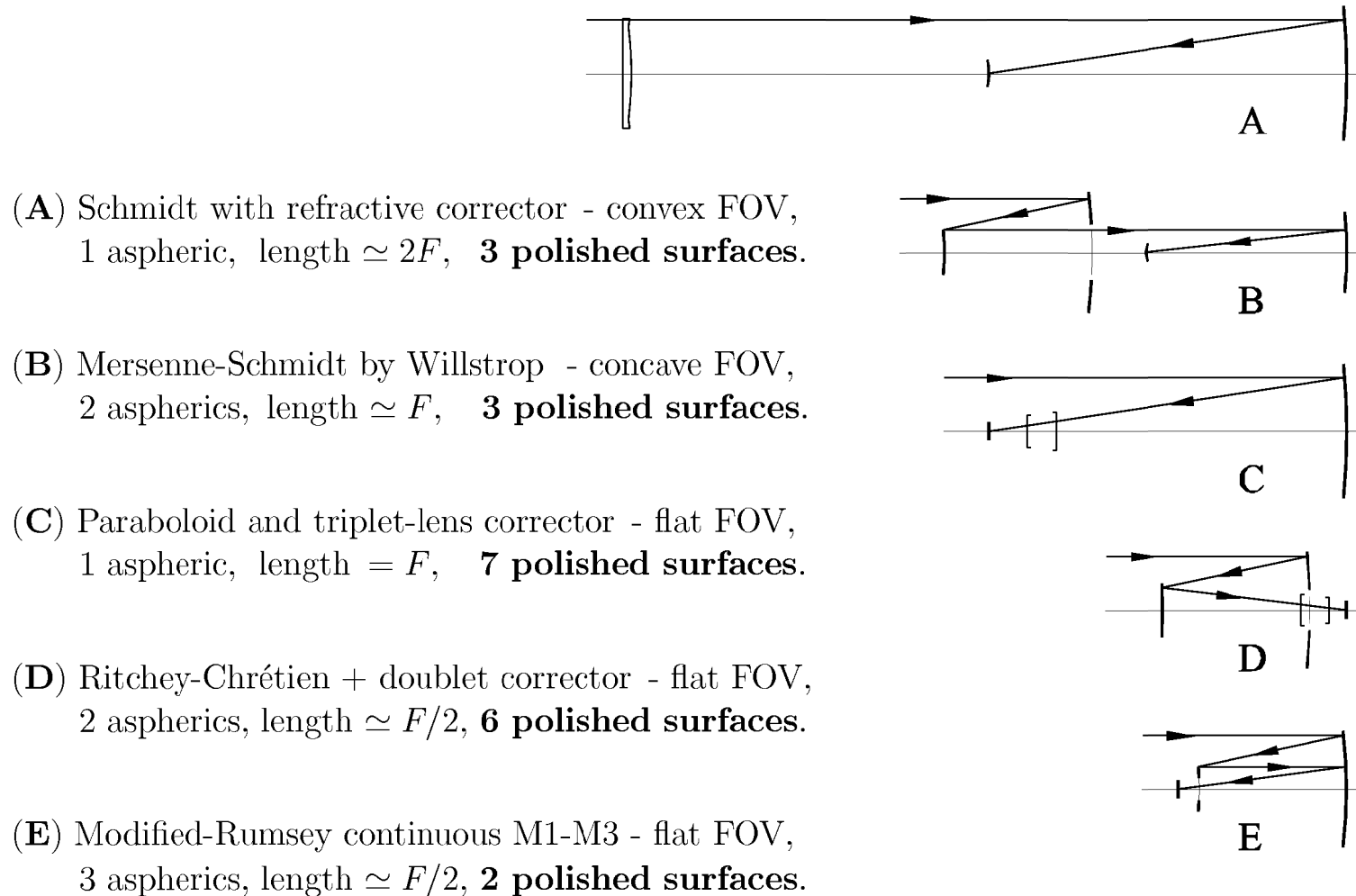

**Fig. 1** - Telescopes with identical input beam aperture, focal length and field of view.

## EXISTING IMAGING SURVEY TELESCOPES :

- Spitzer IR 3-700 $\mu\text{m}$  (space) : Design (**D**) = 6 opt. surf.,  $d_1 = 0.8 \text{ m}$ ,  $f/12$ , FOV  $1.1 \times 1.1^\circ$ .
- SDSS - Sloan Digital Sky Survey: Design (**D**) = 6 opt. surf.,  $d_1 = 2.5 \text{ m}$ ,  $f/5$ , FOV  $2.0 \times 1.5^\circ$ .
- VST - VLT Survey Telescope: Design (**D**) = 6 opt. surf.,  $d_1 = 2.6 \text{ m}$ ,  $f/5$ , FOV  $1.0 \times 1.0^\circ$ .
- CFHT - PF with Megacam : Design (**C**) = 7 opt. surf.,  $d_1 = 3.6 \text{ m}$ ,  $f/4$ , FOV  $1.0 \times 1.0^\circ$ .
- VISTA Visible + NIR: Design (**D'**) = 8 opt. surf.,  $d_1 = 4.0 \text{ m}$ ,  $f/3.3$ , FOV  $1.5 \times 1.1^\circ$ .
- Converted MMT + Megacam: Design (**D'**) = 6 opt. surf.,  $d_1 = 6.5 \text{ m}$ ,  $f/5$ , FOV  $0.4 \times 0.4^\circ$ .

## PRESENTLY PROPOSED SURVEY TELESCOPE :

→ Design (**E**) = 2 opt. surf. to polish

→ R&T results of a prototype telescope: MINITRUST

G.R. Lemaitre, P. Montiel, P. Joulié, K. Dohlen, P. Lanzoni,  
**Appl. Opt.**, Vol. 44, No. 34, 7322-7332 (2005)

## 2. Optical Design of a Modified-Rumsey : MiniTrust-1 and -2

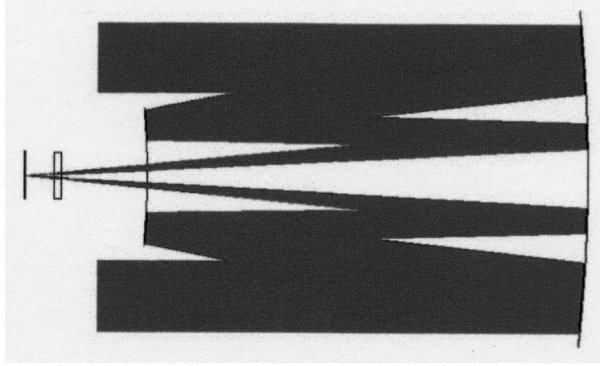

**Fig. 2** - Optical scheme (on-axis beams).

**Table 1.** MINI TRUST optical design – Aperture 450 mm – f/5 –  $1.5 \times 1.5^\circ$  FOV –  $\lambda \lambda [380-900 \text{ nm}]$

Surface	$R$	$z$	$A_4$	$A_6$	Clear Aperture	$(\kappa \text{ (*)})$
Primary	-2208.0	-630.000	$6.3905 \cdot 10^{-12}$	$3.1327 \cdot 10^{-19}$	450	(-1.5503)
Secondary	-1096.0	630.005	$2.7995 \cdot 10^{-10}$	$-2.4184 \cdot 10^{-16}$	Stop 200	(-3.9485)
Tertiary	-2197.2	-763.403	$7.5810 \cdot 10^{-11}$	$-6.9152 \cdot 10^{-17}$	180	(-7.4332)
Filter +	$\infty$	-10.000			$59 \times 59$	
fused silica	$\infty$	-25.000			$58 \times 58$	
Focus	$\infty$				$56 \times 56$	

Mirrors :  $z = (1/2R)r^2 + A_4r^4 + A_6r^6$ . (\*) Equivalent conic constant ( $\kappa = -1$  paraboloid).

Sag and slope continuities of  $M_1 - M_3$  at  $d_{3 \max} = d_{1 \min} = 180 \text{ mm}$ . Dimensions: [mm]

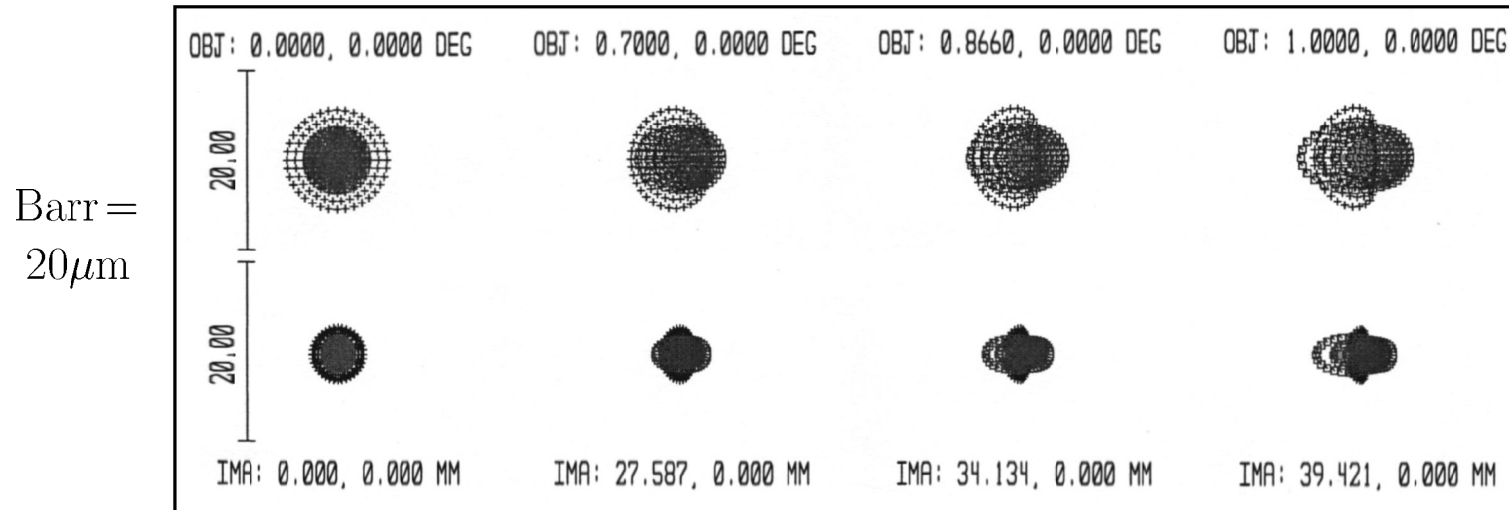

**Fig. 3** - RESIDUAL BLUR IMAGES from Table 1 parameters ( $2^\circ$  diagonal FOV).

( *Up* ) Thickness of (filter + detector window) = 10 mm. RMS diameter of blur images  $\leq 9\mu\text{m}$ .

( *Down* ) Thickness of (filter + detector window) = 5 mm. RMS diameter of blur images  $\leq 5\mu\text{m}$ .

→ Sphero-chromatism of (filter + detector window) dominating.

The above telescope is designed with the continuity of both sags and slopes at the  $M_1$ - $M_3$  boundary. The image quality is completely equivalent to the three-mirror design originally proposed by Norman Rumsey<sup>(1)</sup> in 1969.

### 3. Active Optics Methods

#### ADVANTAGES OF ACTIVE OPTICS :

- **generate smooth** and **accurate** optical surfaces with elastic linear materials (Hooke's law).
- **avoid the slope discontinuities** of the optical surface i.e. cancels the high spacial frequency errors.  
(inherent to local polishing tools)
- **generate non-axisymmetrical** and **variable-shape** optics.<sup>(2)</sup>  
(vase form, meniscus form, tulip form, cycloid-like form, ...)
- **provide optics of the highest intrinsic quality**, then recommended for a site with excellent seeing.

## FIELD DEVELOPMENTS OF ACTIVE OPTICS :

1 - Large amplitude aspherization of optics by **stress polishing** and/or by **in situ stressing**.

**Stress polishing** → Schmidt plates, Keck segments, Cassegrain secondaries (THEMIS), etc

**In situ stressing** i.e. aspherization at the telescope → ( M<sub>2</sub>-TEMOS, M<sub>1</sub>-segments LAMOST)

2 - **In situ compensation** of large telescope mirrors due their deflection in field gravity (M<sub>2</sub>-CFHT, M<sub>1</sub>-VLT ).

3 - **Variable asphericity mirrors** for multi-focii telescopes selected by focus interchange (VLT Cass.–Nasmyth).

4 - **Variable curvature mirrors** for field compensation and cophasing of optical telescope arrays (VLTi, GI2T).

5 - Segments and diffraction gratings aspherized by **replication techniques** from **active submasters**.

**Aspherized gratings** of many spectrographs (SOHO MISSION, OSIRIS OBSERVER, Ground-based)

6 - Mirror **concept** with the superposition capability of aberration modes for **adaptive optics systems**.

#### 4. Vase Form Mirrors and the Theory of Shells

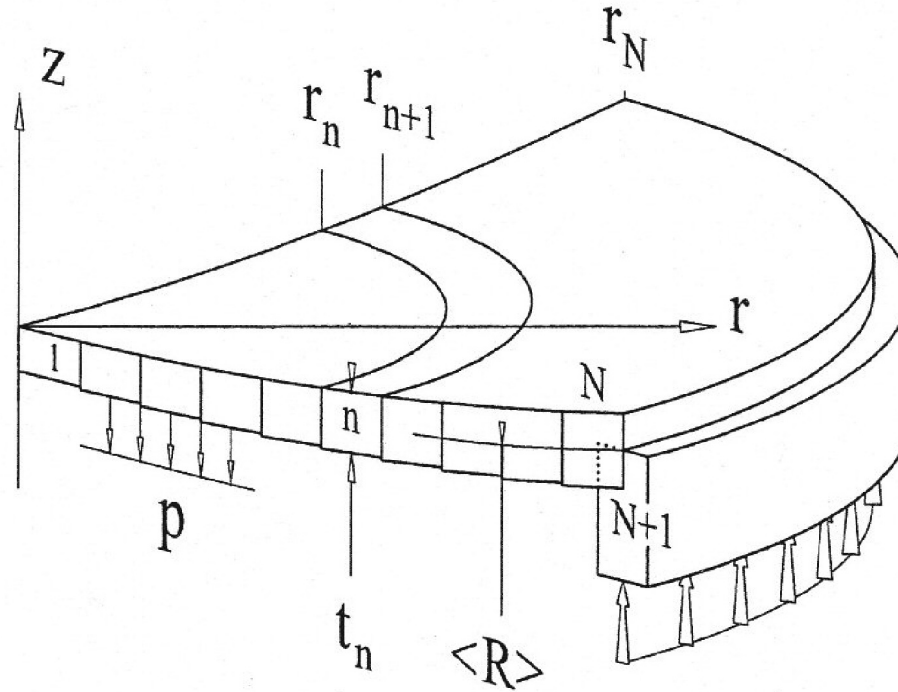

**Fig. 4** - THEORY OF SHELLS: Geometrical parameters of element rings.

$$z_{\text{Optic}} = z_{\text{Sphere}} + z_{\text{Flexure}}$$

UNKNOWNs:  $z_{\text{Sphere}}$ ,  $z_{\text{Flexure}}$ ,  $t(r)$  and  $p$ .

## 5. Elasticity Design of MiniTrust $M_1$ - $M_3$ Substrate

**Table 2** - Thickness distribution  $t(r)$  of  $M_1$ - $M_3$  substrate - DOUBLE VASE FORM.  
 Zerodur:  $\nu = 0.240$ ,  $E = 920 \cdot 10^3 \text{ kgf/cm}^2$ . Load  $p = -0.8 \text{ kgf/cm}^2$ . Dimensions [mm]

$r$	0	18	36	45	54	63	72	81	90 <sup>-</sup>		
$t(r)$	12.042	12.044	12.053	12.061	12.070	12.082	12.096	12.112	12.130		
$r$	90	110	110 <sup>+</sup>	132	154	176	198	220 <sup>-</sup>	220	240	
$t(r)$	30.190	30.183	20.317	20.402	20.502	20.617	20.741	20.868	68	68	

**Fig. 5** - ALTERNATIVE GEOMETRIES  
 FOR A DOUBLE-VASE FORM SUBSTRATE<sup>(3)</sup>

*Design A*: with cylindric outer ring

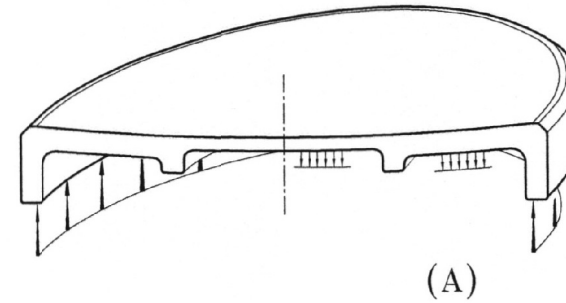

*Design B*: with L-shaped outer ring

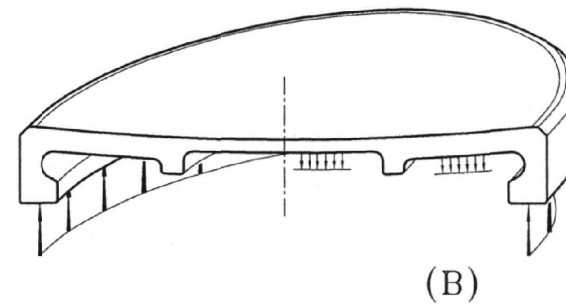

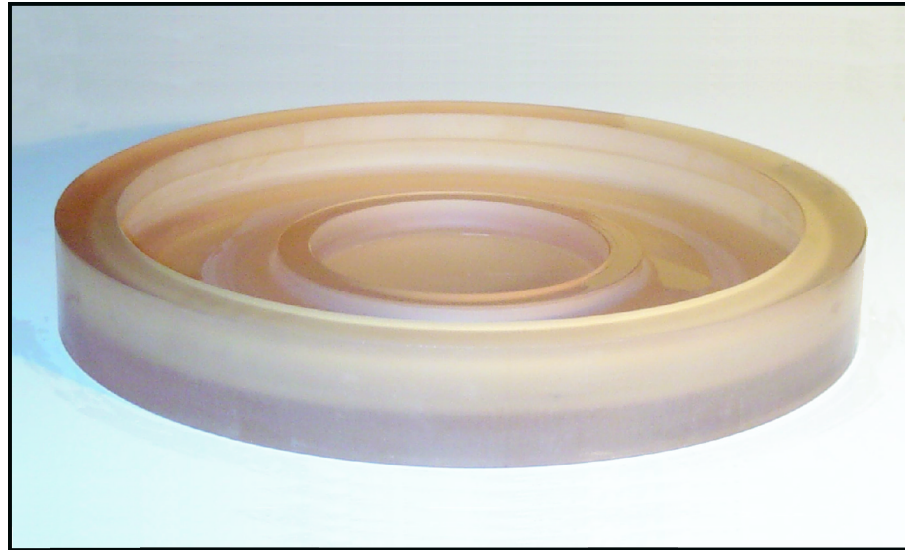

**Fig. 6** - REAR VIEW OF  $M_1$ - $M_3$  SUBSTRATE.

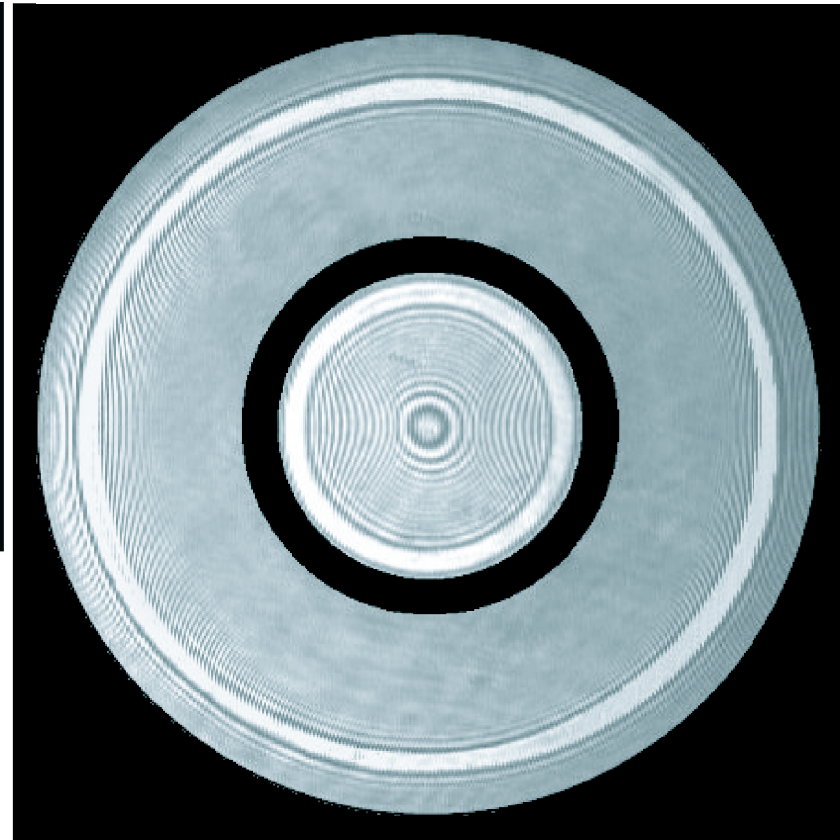

**Fig. 7** - IN-SITU STRESSING - He-Ne Fizeau interferograms of  $M_1$  and  $M_3$ .

Autocollimations achieved at  $\sqrt{3}/2$  of clear aperture radius  $r_{max}$  with respect to a sphere.  
Aperture radii:  $r_{1max} = 220$  and  $r_{3max} = 90$  mm. From  $M_1$  interferogram, the source is moved of 13.32 mm towards the substrate to get  $M_3$  interferogram.

## 6. Elasticity Design of M<sub>2</sub> Substrate by Stress Polishing

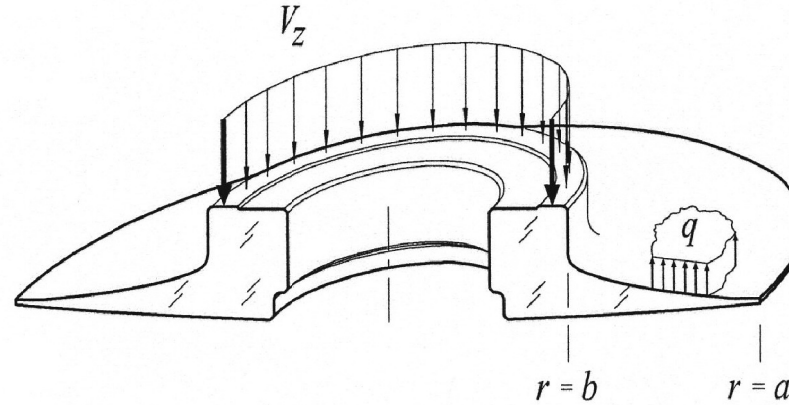

**Fig. 8** - TULIP FORM elasticity design of M<sub>2</sub> substrate.

**Table 3** - Thickness distribution  $t(r)$  of M<sub>2</sub> substrate – TULIP FORM.

Zerodur:  $\nu = 0.240$ ,  $E = 920 \cdot 10^3 \text{ kgf/cm}^2$ . Load  $p = -0.8 \text{ kgf/cm}^2$ . Dimensions [mm]

Clear aperture radii  $50 \leq r \leq 100$ . Outer edge  $r_{\text{ext}} = 103$ . Stress  $\sigma_{\text{max}} = 64 \text{ kgf/cm}^2$ .

$r$	30	50	50 <sup>+</sup>	60	70	80	85	90	95	100	103
$t(r)$	32.000	31.273	14.343	9.997	7.108	4.896	3.926	2.999	2.069	1.042	0.308
$z_B$ (*)			9.318	5.471	3.173	1.641	1.044	0.512	0.200	0.000	0.000

(\*)  $z_B$  represents the shape of rear surface when not stressed. This surface ends flat at the edge.

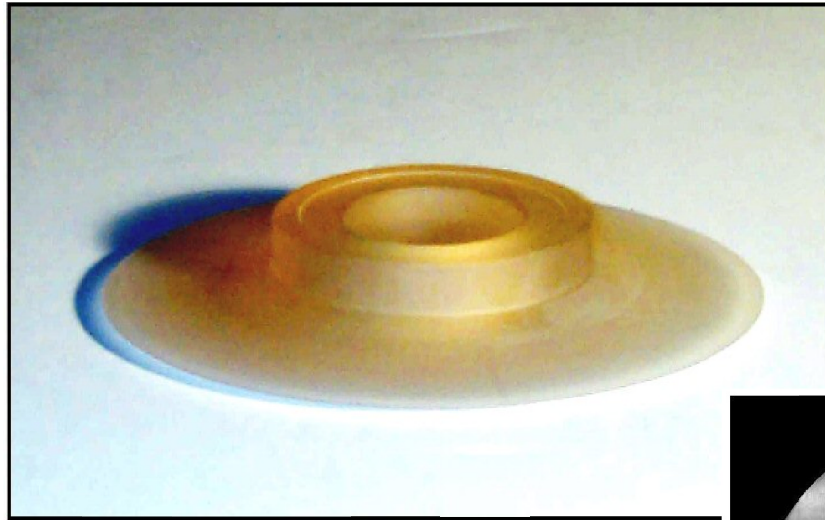

**Fig. 9** - REAR VIEW OF  $M_2$  MIRROR.

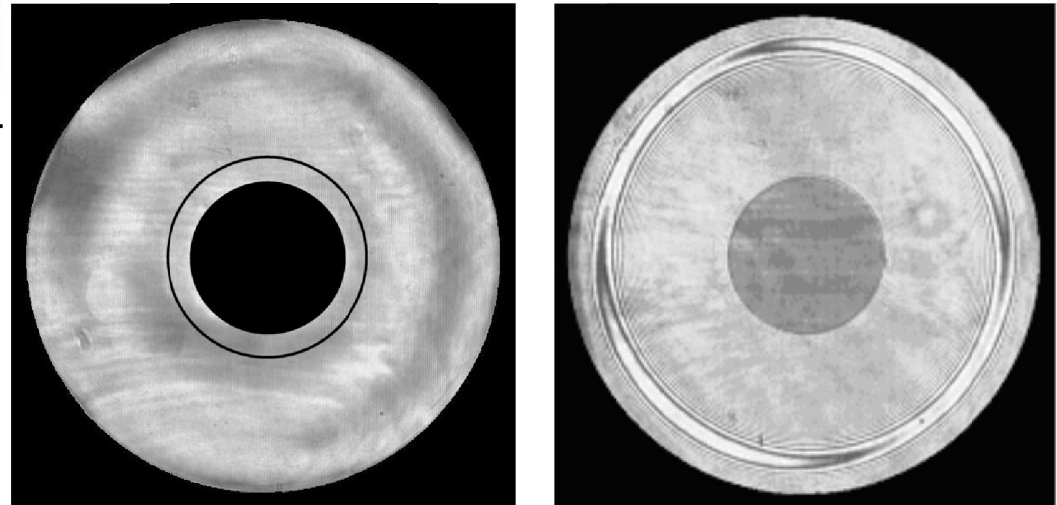

**Fig. 10** - STRESS POLISHING - He-Ne Fizeau interferograms.

[ *Left* ] Mirror shape during stressing.

[ *Right* ] Shape after elastic relaxation.

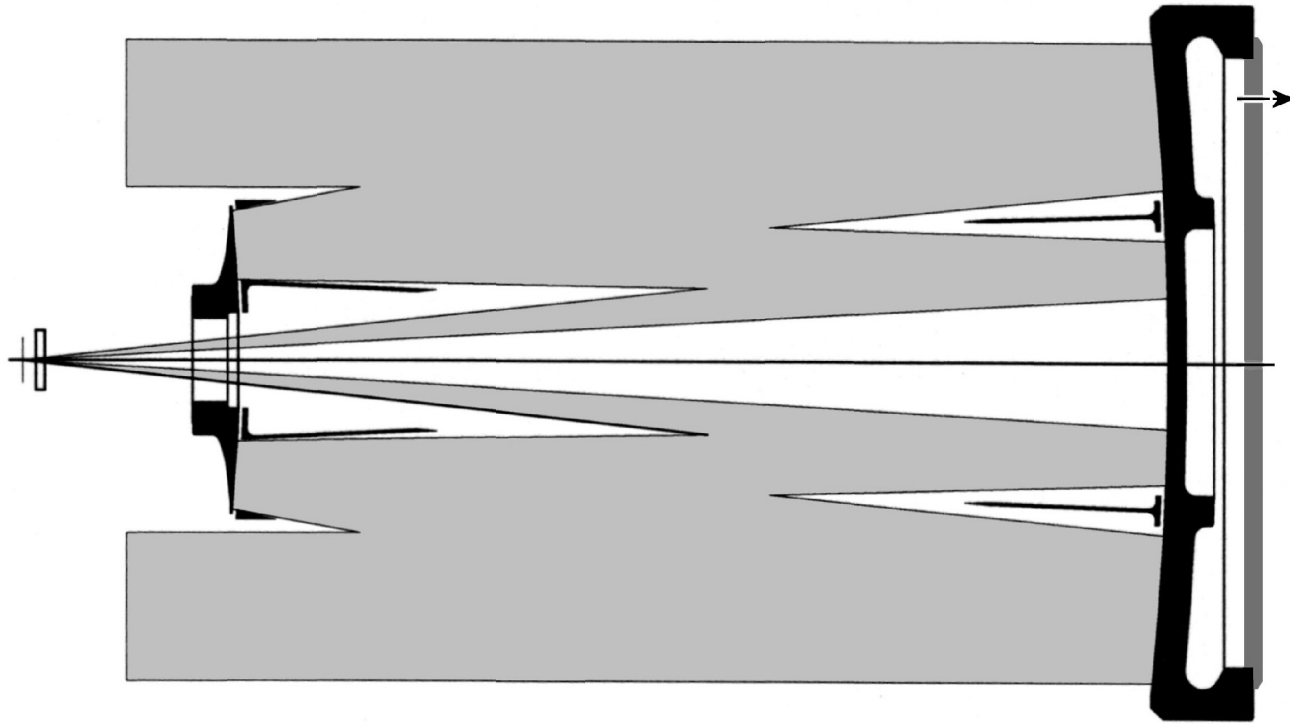

**Fig. 11** - MINI TRUST FINAL DESIGN.

Entrance pupil on  $M_2$  - Substrates - On-axis beam - Baffles.

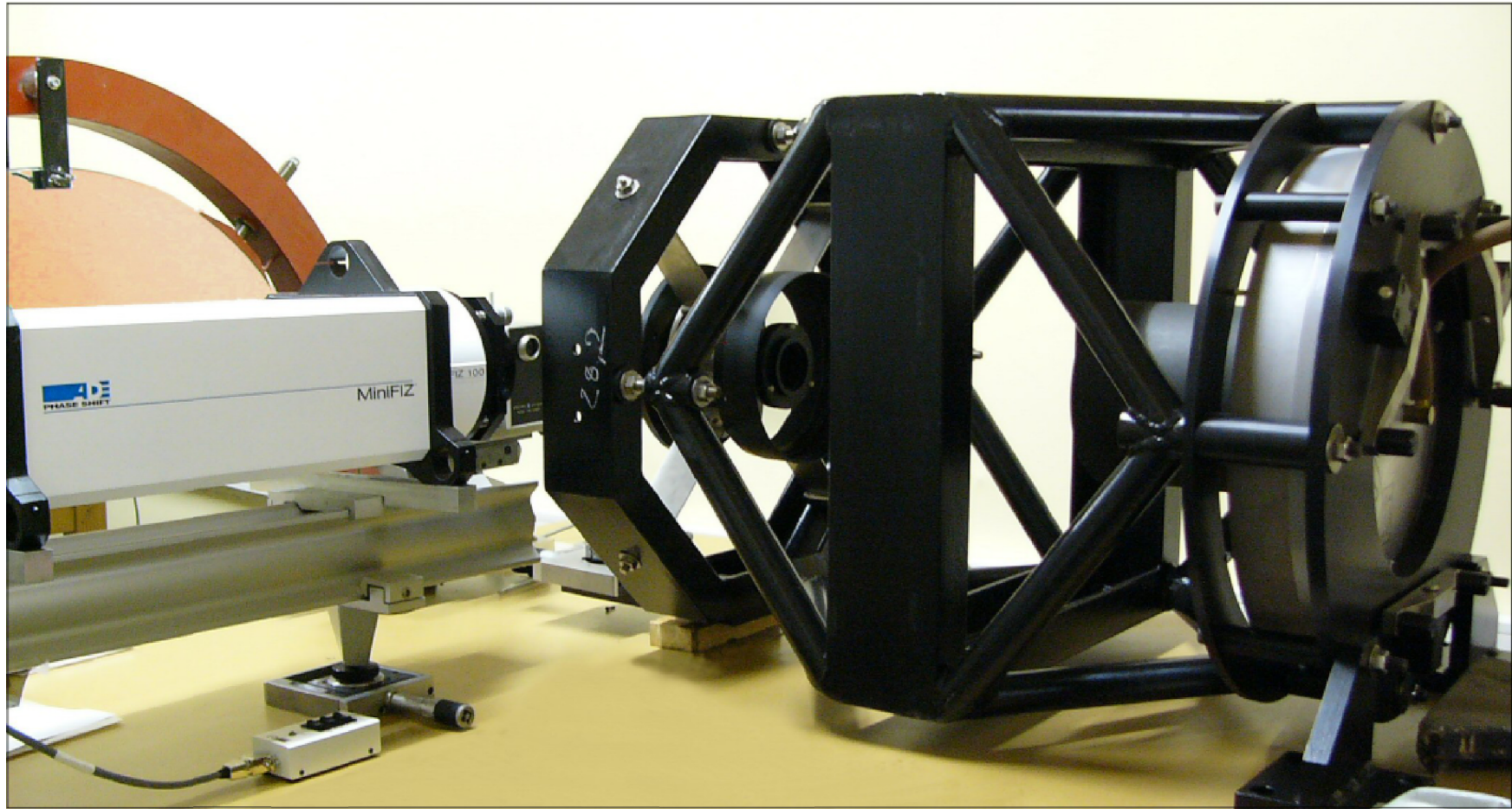

**Fig.12** - VIEW OF MINI TRUST-1.

Alignment and double-pass testing by auto-collimation on a plane mirror.

## 7. Interferometric Results from MiniTrust-1 Integration

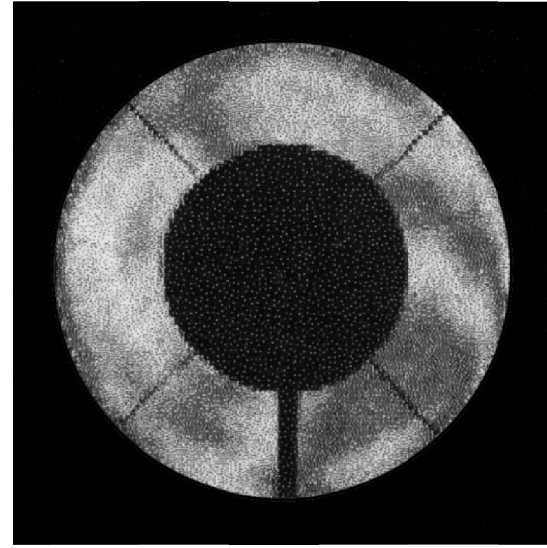
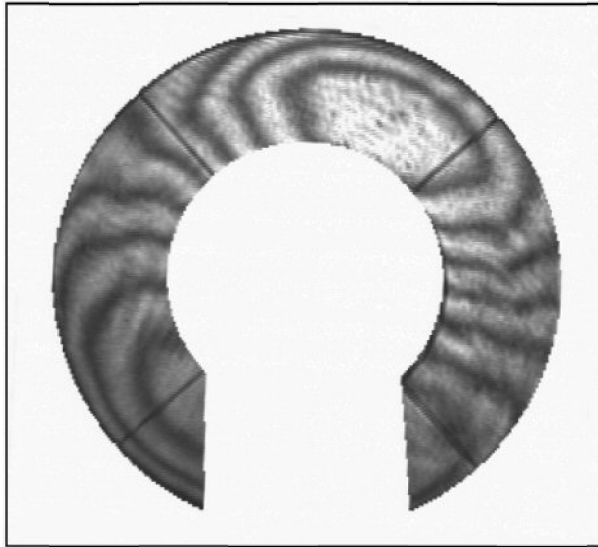

**Fig. 13 - MINI TRUST-1 OPTICAL TESTS:** He-Ne wavefronts after double pass.  
*Left:* Decentering coma before  $M_2$  set up.      *Right:* Wavefront after  $M_2$  set up.

FINAL DATA REDUCTION FROM MINIFIZ PHASE-SHIFT INTERFEROMETER.

Residual PtV onto the wavefront issued from double pass :

$$Sph\ 3 = 0.06\ \lambda, \quad Coma\ 3 = 0.07\ \lambda, \quad Astm\ 3 = 0.42\ \lambda.$$

Must be divided by two for a wavefront from a star  $\rightarrow$  Sum including all aberrations :

$$\mathbf{0.280\ \lambda_{He-He}\ PtV} \quad \Leftrightarrow \quad \mathbf{0.048\ \lambda_{He-Ne}\ RMS.}$$

## 8. TRSS Proposal: A Three Reflection Sky Survey at DOME C

2-METER MODIFIED-RUMSEY TELESCOPE –  $f/5$  –  $2^\circ$  DIAGONAL FOV

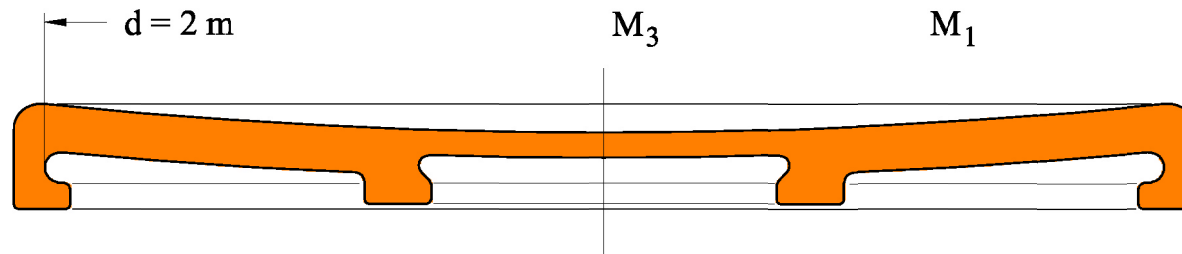

**Fig. 14** - ELASTICITY DESIGN OF  $M_1$  -  $M_3$  SUBSTRATE  
WITH CONTINUITY OF BOTH SAGS AND SLOPES AT THE INTERMEDIATE BOUNDARY <sup>(4)</sup>

**Table 4 - OPTICAL DESIGN OF A 3-METER MODIFIED-RUMSEY TELESCOPE.**

f/5 – 2° diagonal FOV –  $\lambda\lambda$  [350-2300 nm] – M<sub>1</sub>-M<sub>2</sub> continuity of slopes and sags at  $r = 560$  mm.

Surface	$R$	$z$	$A_4$	$A_6$	Clear Aperture	( $\kappa$ )
Primary	-13298.8	-3936.356	$2.4238 \cdot 10^{-14}$	$5.674 \cdot 10^{-23}$	3000	(-1.452)
Secondary	-6577.6	3936.398	$1.4074 \cdot 10^{-12}$	$-3.208 \cdot 10^{-20}$	Stop 1140	(-4.204)
Tertiary	-13204.3	-4142.290	$4.5446 \cdot 10^{-13}$	$-5.116 \cdot 10^{-21}$	1100	(-9.370)
Filter +	$\infty$	-20.000			348×348	
window	$\infty$	-50.000			346×346	
Focus	$\infty$				341×341	

Equation of mirrors:  $z = (1/2R)r^2 + A_4 r^4 + A_6 r^6$ . Conic constant:  $\kappa$ . Dimensions: [mm]

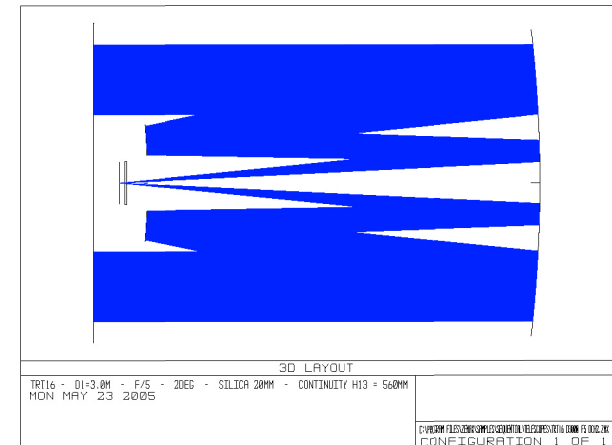
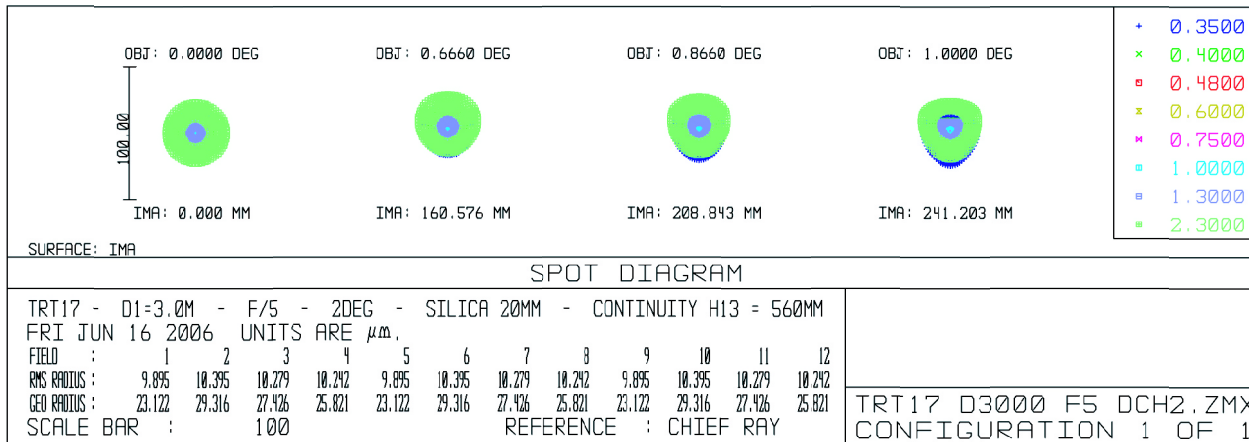

RMS diameter of blur images:  $20.5 \mu\text{m} \equiv 0.28 \text{ arcsec} \rightarrow$  excellent site

## 9. Conclusions for a TRSS Telescope

- Telescope features : → **compact, minimum number of optical surfaces (3)**
- Telescope throughput : → **optical coatings of only 2 surfaces**
- Completely achromatic : → **superiority in image quality from UV to IR,  
RMS blur images = 1/4 arcsec = Excellent Site**
- Telescope optics set up : → **no off-centering of  $M_3$  with  $M_1$**
- Supporting of optics : → **perimeter points of  $M_1$ - $M_3$  substrate on  $M_3$  edge**
- Gravity compensation : → **small uniform load all over  $M_1$ - $M_3$  substrate**
- Obstruction and baffling : → **equivalent to the design (D) in Fig. 1**
- Active optics aspherization : → **all optics with only 2 spherically polished surfaces,  
i.e. Minimum Cost**  
→ **the best intrinsic image quality**

This proposal is presently investigated in the framework of a collaboration between the IASF-Roma and OAMP-Marseille<sup>(4-7)</sup> and could be extended to other interested institutes.

## References

### ON ACTIVE OPTICS AND THREE REFLECTION TELESCOPES (TRTs)

- 1 - N.J. Rumsey, A compact three-reflection astronomical camera, in *Optical Instruments and Techniques*, ICO 8 Meeting, London, Home Dickson ed., Oriel Press Newcastle, 514-520 (1969)
- 2 - G.R. Lemaître, Active Optics and the Non-Axisymmetric Case: Multimode deformable mirrors aspherized from Vase and Meniscus form, in *Astronomical Telescopes and Instrumentation* - Glasgow, E. Atad-Ettinger & P. Dierickx, SPIE Proc. **5494**, 101-112 (2004)
- 3 - G.R. Lemaître, P. Montiel, P. Joulé, K. Dohlen, P. Lanzoni, Active Optics and modified-Rumsey wide field telescopes: MINISTRUST demonstrators with Vase and Tulip form mirrors, *Appl. Opt.*, Vol. 44, No. 34, 7322-7332 (2005)
- 4 - G.R. Lemaître, TRSS: A Three Reflection Sky Survey at Dome-C, in Conference Proc. on WIDE FIELD SURVEY TELESCOPE ON DOME C, June 3-4, 2005 Beijing, and *Acta Astronomica Sinica Supplement*, Chinese Astronom. Soc. (in press)

### ON TRTs AND PROPOSALS TO DOME C (COLL. IASF-ROMA – OAMP-MARSEILLE)

- 5 - M. Ferrari, G.R. Lemaître, R.F. Viotti, C. La Padula, G. Comtes, M. Blanc, M. Boer, Three reflection telescope proposal as flat-field anastigmat for wide field observations at Dome C, in *Astronomie et Astrophysique au Dome C* - Toulouse, EAS Publications Series, EDP Sciences, 14, 325-330 (2005)
- 6 - R.F. Viotti, M. Badiali, A. Boattini, A. Carusi, R.U. Claudi, A. Di Lellis, C.D. La Padula, M. Frutti, A. Vignatto, G.R. Lemaître, Wide field observations at Dome C, Antarctica, *Mem. Soc. Astron. Ital. Suppl.*, Italy, **2**, 177-180 (2003)
- 7 - C.D. La Padula, A. Carusi, R.F. Viotti, A. Vignato, G.R. Lemaître, Proposal for a mini-satellite with a wide-field TRT, *Mem. Soc. Astron. Ital.*, Italy, **74**, 63 (2003)